

Crosby® Wide Body Shackles

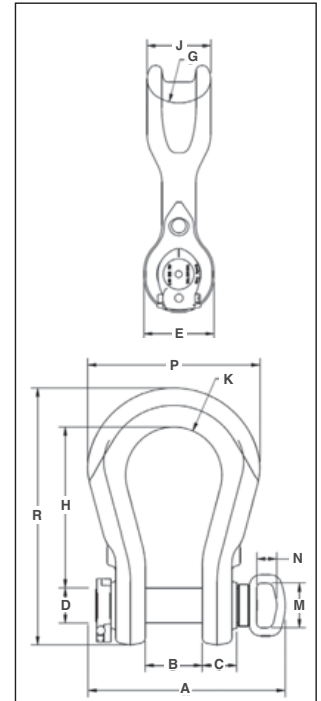

G-2160E

- All sizes Quenched and Tempered for maximum strength.
- Forged alloy steel from 75 through 300 metric tons.
- Proof tested as follows:
 - 7-75 metric tons and 200-300 metric tons: 2 x WLL.
 - 125 metric tons: 1.6 x WLL.
- All ratings are in metric tons, embossed on side of bow.
- G-2160E, (75t and larger), bows are furnished Dimetcoated, and pins are Dimetcoated, then painted red.
- Shackles are **RFID EQUIPPED**.
- Can be used to connect HIGH STRENGTH Synthetic Web Slings, HIGH STRENGTH Synthetic Round Slings or Wire Rope Slings.
- Increase in shackle bow radius provides minimum 58% gain in sling bearing surface and eliminates need for a thimble.
- Increases usable sling strength minimum of 15% and greatly improves life of wire rope slings.
- Approved for use at -40° C (-40° F) to 204 degrees C (400° F).
- Bow and bolt are certified to meet charpy impact testing of 42 Joules (31 ft•lbf) min. avg. at -20° C (-4 degrees F).
- All 2160E shackles are individually proof tested and magnetic particle inspected. Crosby certification available at time of order .
- Shackles requiring ABS, Lloyds and other certifications are available upon special request and must be specified at time of order .
- Shackles have DNV Type Approval to Rules for Certification of Lifting Appliances, and are produced in accordance with DNV MSA requirements. Databook is provided that includes required documents.
 - Serialization / Identification
 - Material Testing (Physical / Chemical / Charpy)
 - Proof Testing
- Look for the Red Pin® . . . the mark of genuine Crosby quality.



Shackles



SEE APPLICATION INFORMATION
 On Page 92 of the General Catalog
 Para Español: www.thecrosbygroup.com

G-2160E Crosby® Easy-Loc “Wide Body” Shackles

Working Load Limit (t)*	Stock No.		Weight Each (kg)	Dimensions (mm)														Effective Body Diameter
	G-2160E	S-2160E		A	B +/- 6.35	C	D +/- .5	E	G	H	J	K	M	N	P	R		
75	1021500	–	49.9	382	105	60.7	69.9	136	95.3	293	127	92.5	102	45.7	321	474	160	
125	1021509	–	86.2	450	130	78.7	80.0	165	95.3	365	150	110	102	45.7	393	584	173	
200	1021518	–	185	491	150	86.1	105	214	133	480	219	138	102	45.7	515	773	241	
300	1021527	–	357	574	187	109	133	267	156	600	264	160	102	45.7	608	953	290	

*Note: Maximum Proof Load is 2 times the Working Load Limit on 75 thru 300 metric tons (except for 125 metric tons which is proof tested to 1.6 times the Working Load Limit). Minimum Ultimate Load is 5 times the Working Load Limit on 75 thru 300 metric tons.